

# Specialty Compactors



**CRAM-A-LOT®**  
J.V. Manufacturing, Inc.   
Solid Waste & Recycling Equipment



**GSA**  
Federal Supply Service



**“Equipping The World For A Better Environment”**

# Features

Our Cram-A-Lot specialty compactors are designed specifically for facilities to save space where overall space utilization is critical.

## THESE POWERFUL UNITS ARE IDEAL FOR:

- Facilities with limited floor space
- Warehouses
- High-Rise Apartments
- Hotels, Offices & Hospitals
- Or anywhere else trash space is very limited

SAFE  
SIMPLE  
AND  
USER  
FRIENDLY

## DESIGNED FOR:

- Ease of Installation
- Ease of Operation
- Ease of Maintenance

## X-PRESS PACK

Portable Liquid Tight Self-Contained Unit

Ease of usage makes it a perfect portable trash compactor ready to use and requires no additional sight prep such as concrete pad, anchors or channel guides.



## VERTICAL COMPACTOR

Small Footprint, Frontload service

This compact liquid tight compactor/container is designed to eliminate the need for multiple front load containers. Loading capabilities from the ground, off a dock, or through the wall with optional chute fed systems available.



## APARTMENT COMPACTOR

Extra Tight Space Problems

Designed to solve those extra tight space problems, the apartment compactor packs into a 2yd or 3yd front load or rear load container. These units can be equipped with high-rise chute hoppers, ground feed hoppers, and any other special installation solution requirement.



## CS-01 & CS-02

Limited volume applications

For restrictive applications, we offer a 1 or 2 yard short version of our standard commercial compactor.



# Installed Applications



**CRAM-A-LOT®**  
J.V. Manufacturing, Inc.  
Solid Waste & Recycling Equipment

**Vertical Compactor**



**X-Press Pack**



**CS-02**



**CS-01**



**Apartment Compactor**



**Apartment Compactor**



# Apartment Compactor

**CA.5 1/2 Yard Space Saver Single Cylinder**

**CS.5 1/2 Yard Space Saver w/Twin Cylinders**

## FEATURES

- UL/CUL listed Control Panel
- Single side latching for easy and quick container removal
- ANSI Z245.21 Compliant
- Quiet Operating Vane Pump
- Key operated controls
- Can be equipped with high-rise chute hoppers, ground feed hoppers, and any other special installation solution requirement
- Space saver design
- Special modifications quoted upon request



**Cram-A-Lot Apartment Compactors are designed to pack into a 2yd or 3yd Front Load or Rear Load container where overall space utilization is critical**

**These powerful units are the perfect solution for high-rise apartments, hotels, hospitals, and office buildings, or anywhere space is very limited**

## DESIGN FEATURES

- Rugged Construction provides long life
- Compaction ratios average 4 to 1, depending on material
- Excellent Compaction of dry and/or wet material
- Ideal for apartment buildings, hotels, retail shops or anywhere space is limited

## LOADING CAPABILITIES

- Load from ground, off a dock, multi-story chute or through the wall





**CRAM-A-LOT®**  
*J.V. Manufacturing, Inc.*  
**Solid Waste & Recycling Equipment**

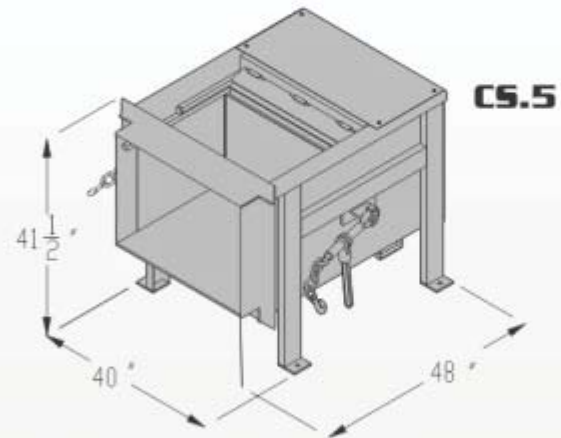
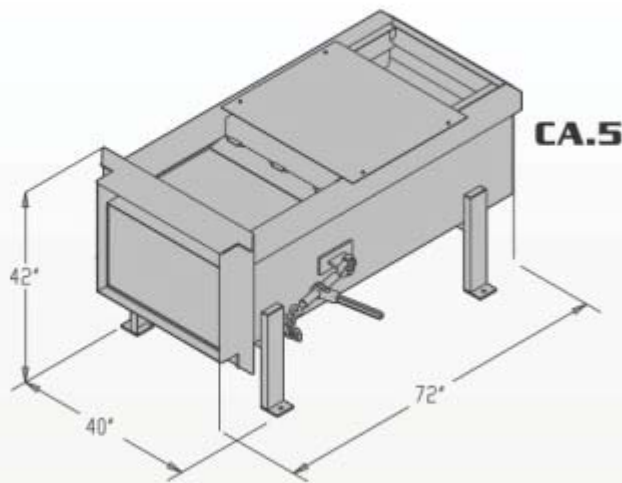

Special modifications quoted upon request

## Specifications

### CA-.5 Specifications

**GENERAL:**

Dimensions	Length	72"
	Width	40"
	Height	42"
Clear Top Opening		20" L x 27" W
Load Height	Min	37 - 1/2"
Cycle Time		38 seconds
Ram Force	Normal	13,800 lbs
	Maximum	17,500 lbs
Ram Penetration		5.5"
Ram Face Dimensions		29 - 3/4" W x 18" H
Weight		1,840 lbs with hopper
WASTEC Rated		.27 CU YDS

**CONSTRUCTION:**

Chassis	Floor	1/4" Steel Plate 3" C-Channel
	Sides	1/4" Steel Plate 4" x 4" x 3/16 Steel Tube 4" C-Channel
Presshead	Top	3/16" Steel Plate
	Sides	1/4" Steel Plate
	Face	3/8" Steel Plate
	Bottom	3/8" AR Steel Plate
Breaker Bar	Guides	HMW Pads
		5" x 3 - 1/2" x 3/8" Steel Angle

**ELECTRICAL:**

Motor	Capacity	3 hp
	Voltage	208 -230/460 VAC 60 Hz Three Phase
Optional Voltage		230 VAC 60 Hz Single Phase

**HYDRAULIC:**

Pump	Type	Vane
	Capacity	4.5 gpm
	Tank Capacity	11 gal
	Bore	4"
Hydraulic Cylinder	Stroke	28"
	Rod	2"
	Operating Pressure	Normal 1,100 psi Maximum 1,400 psi

### CS-.5 Specifications

**GENERAL:**

Dimensions	Length	48"
	Width	40"
	Height	41 - 1/2"
Clear Top Opening		21" L x 28" W
Load Height	Min	39 - 3/4"
Cycle Time		14 seconds
Ram Force	Normal	14,300 lbs
	Maximum	16,400 lbs
Ram Penetration		5.5"
Ram Face Dimensions		29 - 3/4 W x 18 - 3/4 H
Weight		1,186 lbs
WASTEC Rated		.26 CU YDS

**CONSTRUCTION:**

Chassis	Floor	1/2" Steel Plate 3" C-Channel
	Sides	7 gage 4" C-Channel
Presshead	Top	7 gage
	Sides	1/4" Steel Plate
	Face	1/2" Steel Plate
	Bottom	1/2" AR Steel Plate
Breaker Bar	Guides	UHMW Pads
		5" x 3 - 1/2" x 3/8" Steel Angle

**ELECTRICAL:**

Motor	Capacity	5 hp
	Voltage	208 -230/460 VAC 60 Hz Three Phase
Optional Voltage		230 VAC 60 Hz Single Phase

**HYDRAULIC:**

Pump	Type	Vane
	Capacity	6 gpm
	Tank Capacity	11 gal
	Bore	2 - 1/2"
Hydraulic Cylinder (2)	Stroke	18"
	Rod	1 - 1/4"
	Operating Pressure	Normal 1,750 psi Maximum 2,000 psi

All information is subject to engineering and/or other changes without notice.



# CRAM-A-LOT®

J.V. Manufacturing, Inc.

**Solid Waste & Recycling Equipment**



## Leasing and Rental Programs Available

Compactor Units can be custom designed  
and factory installed to suit your special applications

### **Cram-A-Lot® 1-2-3 Warranty**

J.V. Manufacturing will furnish without charge:

- 1) All parts and labor expenses through the first year of ownership to remedy any faults proven to be the result of defective materials or workmanship.
- 2) All parts through the second year of ownership to remedy any faults proven to be the result of defective materials or workmanship.
- 3) All labor expenses through the third year of ownership to remedy any structural faults proven to be the result of defective materials or workmanship.

This warranty does not apply to any damage caused by negligence, misuse, modifications, alterations, or accidents by purchaser or third parties.  
Refer to operation manual for specific warranty coverage.

#### CORPORATE OFFICE

P.O. Box 229  
701 Butterfield Coach Road  
Springdale, AR 72765

1-800-678-7320  
479-751-7320  
479-751-7774 (fax)

#### DISTRIBUTED BY:

[www.cram-a-lot.com](http://www.cram-a-lot.com)