

# Vertical Compactor

Four side loading options.....Five container options....All in ONE unit!!

## FEATURES

- UL/CUL listed Control Panel
- Integral Power Unit
- Key operated controls
- Available with 3, 4, 5, 6 and 8 Yard
- Container Capacities

**Cram-A-Lot Vertical Compactors are designed to allow customized loading options along with versatility in container sizes allowing for volume growth without changing compactors.**

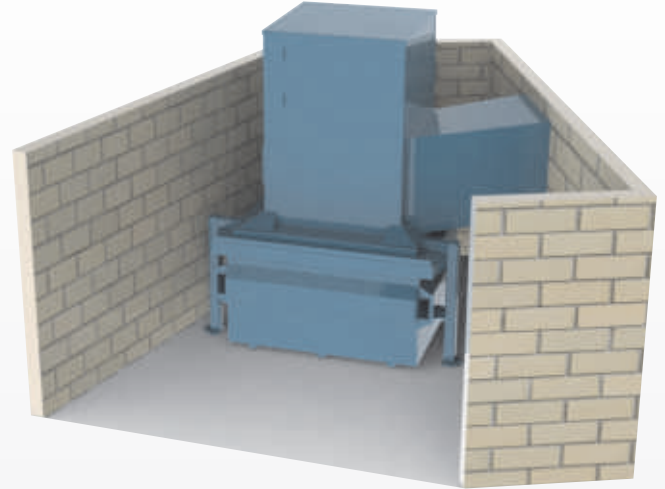

## DESIGN FEATURES

- Vertically adjustable legs allow the compactor to accommodate a 3,4,5, 6 or 8 cubic yard container without changing compactors
- Feed access door is designed to eliminate trash from gathering on top of press head
- No hydraulic lines attached to the container eliminates the need for driver to exit the truck, saving time and money
- Eliminates the mess of spillage when emptying the container
- Rugged construction provides long life
- Compaction ratios average 4 to 1, depending on material mix
- Ideal for Restaurants, Fast Food locations, Shopping Centers, Supermarkets, Hospitals, Schools, Nursing Homes, and Hotels

## LOADING CAPABILITIES

- The VC unit offers loading capabilities from all 4 sides allowing user front, rear or side feed loading and can be combined with an open chute or thru-the-wall access for customized loading access
- Load from the ground, off a dock, or through the wall
- Feed heights starting at 40 1/4"

## USER FRIENDLY

- Convenient location of controls

## SAFETY

- Door Safety Interlock
- Highly visible "Safe To Haul Light"
- Removable key for authorized operator usage





**CRAM-A-LOT®**  
**J.V. Manufacturing, Inc.**  
**Solid Waste & Recycling Equipment**

## Specifications

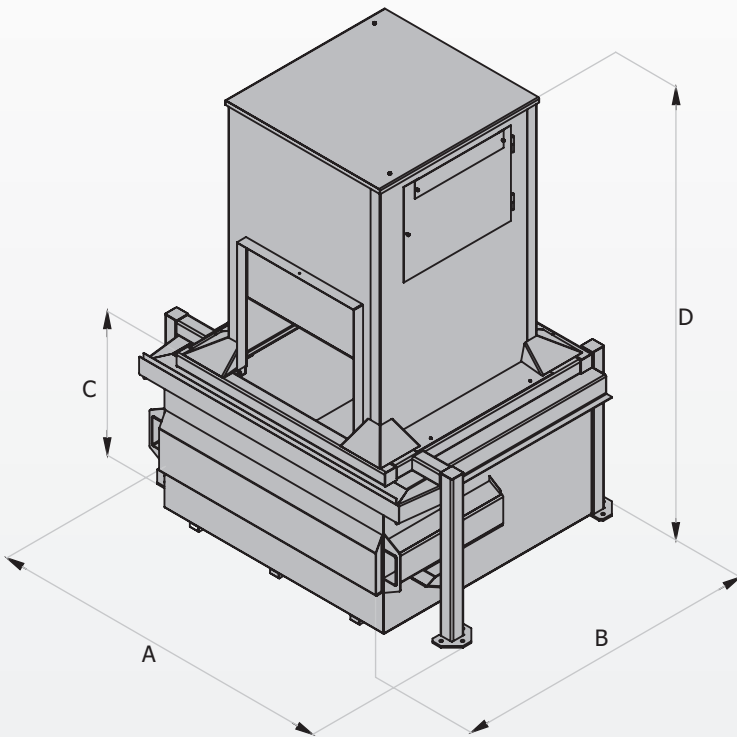

### GENERAL:

Charge Box Capacity	See Chart
Dimensions	See Chart
Clear Top Opening	37 1/4"L x 38"W
Cycle Time	30 sec
Compaction Force	24,700 lbs.
Ram Face Pressure	13 psi
Ram Penetration	10"
Ram Face Dimensions	48"L x 48"W
WASTEC Rated	2.08 Cu YDS

### CONSTRUCTION

#### Container

Floor	11 ga
Sides	11 ga 3" channel
Trim	1-1/2" x 1-1/2" x 11 ga square tube
Lift Pockets	Conform to WASTEC guidelines

#### Presshead

Sides	7 ga
Face	1/4" Steel Plate Vertical Push
Guides	UHMW strips

#### Chassis

Steel tube Frame  
 11 ga. Sheet Steel Shroud

### ELECTRICAL:

Motor	3 hp
Voltage	208/230/460 Vac 60Hz Three Phase (230 Vac 60Hz single phase) ( optional, 1 1/2hp)

### HYDRAULIC:

Pump Type	High/Low Gear
Pump Capacity	8 gpm @1800 rpm
Tank Capacity	8.5 Gal
Hydraulic Cylinder x2	Bore 3" Stroke 37 1/4" Rod Dia. 2"
Operating Pressure	2000 Psi

Special modifications quoted upon request

CONTAINER SIZE / TYPE	A	B	C	D	COMPACTOR WEIGHT
3-YD-FL	100"	79"	40-1/4"	112-5/8"	3892 lbs.
4-YD-FL	100"	79"	46-1/4"	118-5/8"	3973 lbs.
4-YD-RL	82"	100"	46-1/4"	118-5/8"	4050 lbs.
5-YD-FL	100"	79"	56-1/4"	128-5/8"	4183 lbs.
6-YD-FL	100"	95-1/2"	56-1/4"	128-5/8"	4294 lbs.
8-YD-FL	100"	95-1/2"	74"	146-3/8"	4510 lbs.